

# Coburn Sliding Systems Limited

Unit 1, Cardinal way, Cardinal west, Godmanchester, PE29 2XN, UK



## STRAIGHTAWAY

For Timber and Metal Doors operating on Straightaway Gear 2-series, 3-series and 4-series

TO ENSURE SMOOTH OPERATION FOLLOW THIS ASSEMBLY PROCEDURE

A. Securely fix the TRACK BRACKETS to lintel perfectly level throughout and plumb using 'Lock Joint' pattern centrally over track joints. Use of builder's line will assist in getting level and in line. Fixing bolts to be compatible with type of lintel.

B. Fit HANGER TRACK but leave one length out temporarily to allow hangers to be entered.

C. Fix FLOOR CHANNEL so that centre of channel is plumb with centre of top track, using plumb bob hung centrally in track.

D. Drill holes in top edge of door for pendant bolts see table

| Gear       | Dia of hole (mm) | Depth of hole (mm) | Minimum distance from each edge (mm) |
|------------|------------------|--------------------|--------------------------------------|
| 2 - Series | 14 (9/16")       | 38 (1 1/2")        | 65 (2 1/2")                          |
| 3 - Series | 20 (3/4")        | 60 (2 1/4")        | 75 (3")                              |
| 4 - Series | 25 (1")          | 70 (2 3/4")        | 85 (3 1/4")                          |

E. Fix aprons proud on to door - no need to let in.

F. Make recesses for crown nuts allowing 6mm (1/4") lateral movement.

G. Fix aprons to door with crown nuts in position.

H. Take pendant bolt in trolley and screw into crown nut.

K. Raise doors and centre hangers into track, replace length of track left for entry.

L. Adjust hangers to obtain correct clearance under door - see table - adjust laterally as required. Tighten lock nuts.

| Gear         | Clearance |
|--------------|-----------|
| 2/3 - Series | 10 (3/8") |
| 4 - Series   | 12 (1/2") |

M. Fit door stops to prevent hangers clashing closed ends brackets.

N. Clean out channel, grease copiously inside of the top track (only if using steel wheel hangers, if using plastic wheels hangers do not grease the track), and repeat at intervals, checking also bolts, nuts and screws for tightness.

These instructions should be treated as general guidance instructions; variations to the procedure may change depending upon site requirements.

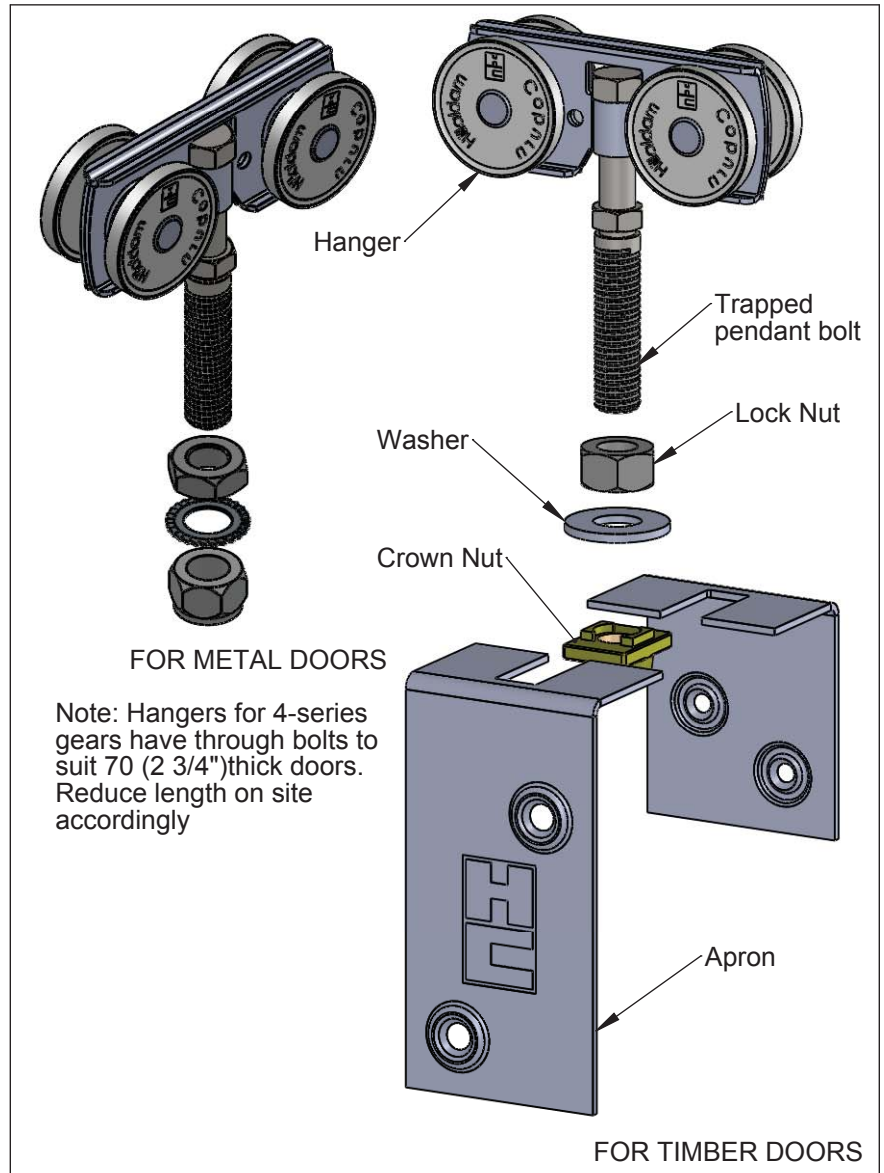

When Doors are draught proofed width of packing to be increased

| Gear       | Door thickness | Packing |
|------------|----------------|---------|
| 2 - Series | 44 (9/16")     | 12      |
| 3 - Series | 44 (9/16")     | N/A     |
| 4 - Series | 57 (9/16")     | 5       |

| Dimension Y1 |              |
|--------------|--------------|
| Gear         | Y1           |
| 2 - Series   | 30 (1 3/16") |
| 3 - Series   | 38 (1 1/2")  |
| 4 - Series   | 40 (1 3/5")  |

| Depth of Hole in Door |             |
|-----------------------|-------------|
| Gear                  | Depth       |
| 2 - Series            | 38 (1 1/2") |
| 3 - Series            | 60 (2 1/4") |
| 4 - Series            | 70 (2 3/4") |

| Hole For Pendant Bolt Steel Door |            |
|----------------------------------|------------|
| Gear                             | Hole Dia   |
| 2 - Series                       | 14 (9/16") |
| 3 - Series                       | 20 (3/4")  |
| 4 - Series                       | 25 (1")    |

| Gear         | Clearance X1 |
|--------------|--------------|
| 2/3 - Series | 10 (3/8")    |
| 4 - Series   | 12 (1/2")    |

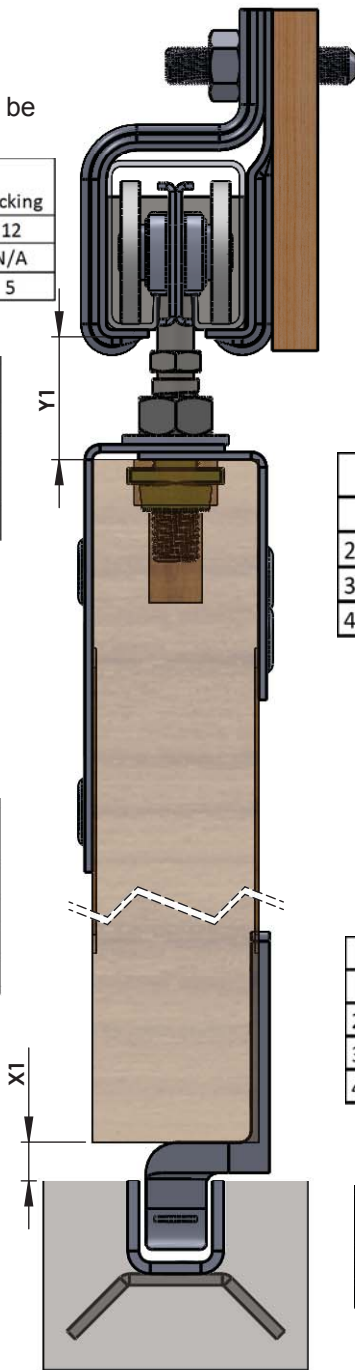

| Dimension Y2 |              |
|--------------|--------------|
| Gear         | Y2           |
| 2 - Series   | 30 (1 3/16") |
| 3 - Series   | 38 (1 1/2")  |
| 4 - Series   | 40 (1 3/5")  |

| Hole For Pendant Bolt Steel Door |              |
|----------------------------------|--------------|
| Gear                             | Hole Dia     |
| 2 - Series                       | 12 (1/2")    |
| 3 - Series                       | 18 (1 1/16") |
| 4 - Series                       | 21 (1 3/16") |

| Hole Diameter |            |
|---------------|------------|
| Gear          | Dia        |
| 2 - Series    | 14 (9/16") |
| 3 - Series    | 14 (9/16") |
| 4 - Series    | 14 (9/16") |

| Gear         | Clearance X2 |
|--------------|--------------|
| 2/3 - Series | 10 (3/8")    |
| 4 - Series   | 12 (1/2")    |

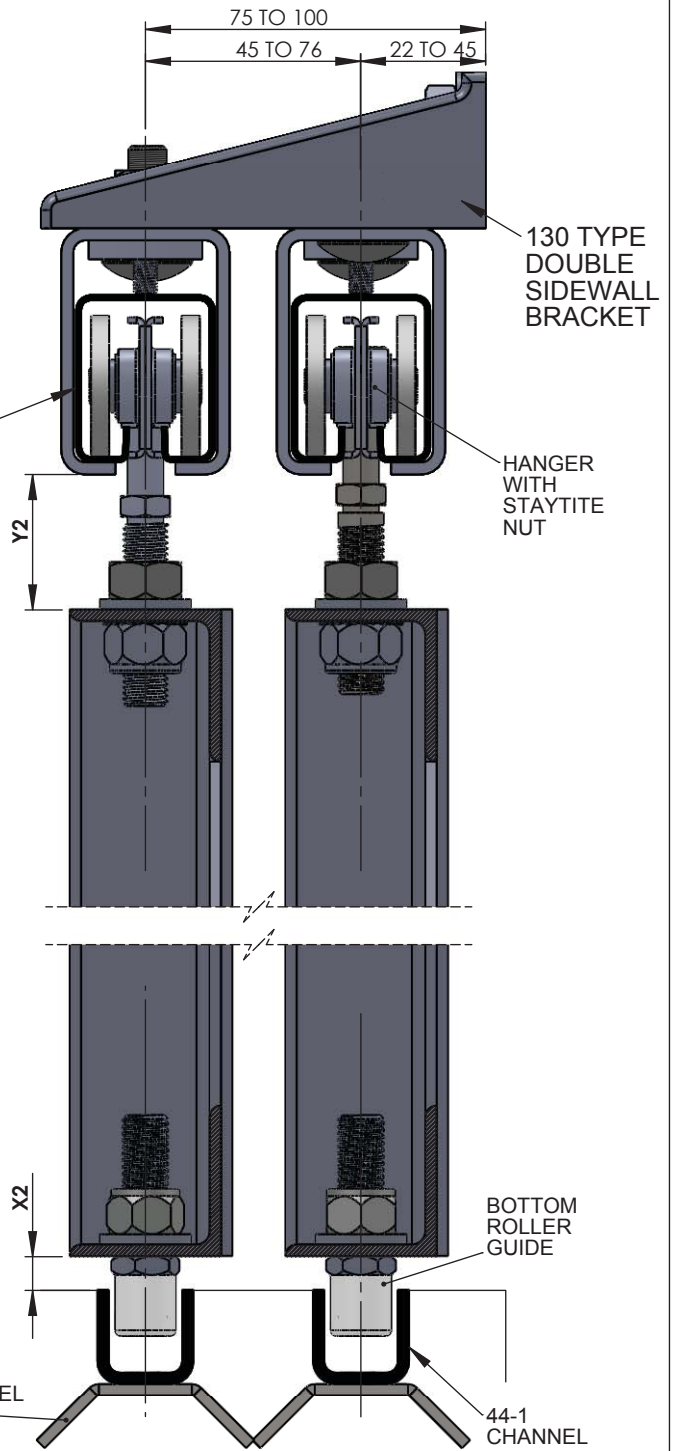

BRACKET CENTRES @  
 Straightaway 2/3-series 900mm(3'.0") MAX  
 Straightaway 4-series 800mm(2'.8") MAX

| Holes Drilled minimum distance from Edge |            |
|--|------------|
| Gear                                     | Z          |
| 2-series                                 | 65 (2.5")  |
| 3-series                                 | 75 (3")    |
| 4-series                                 | 85 (3.25") |

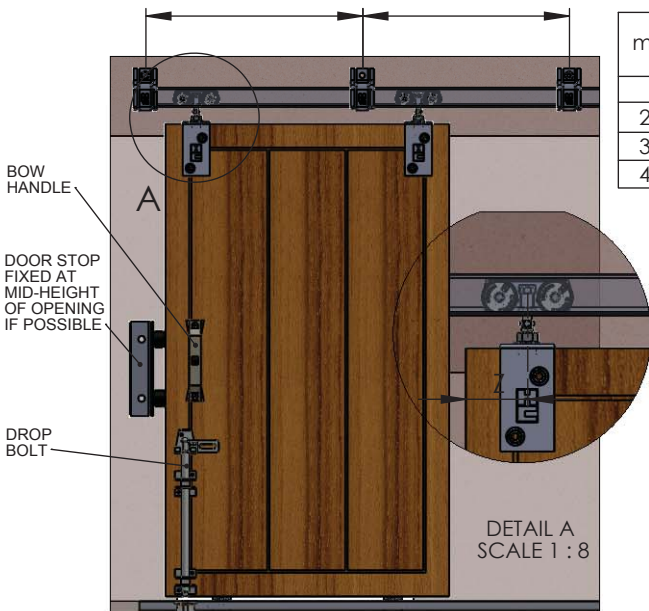

Timber door elevation

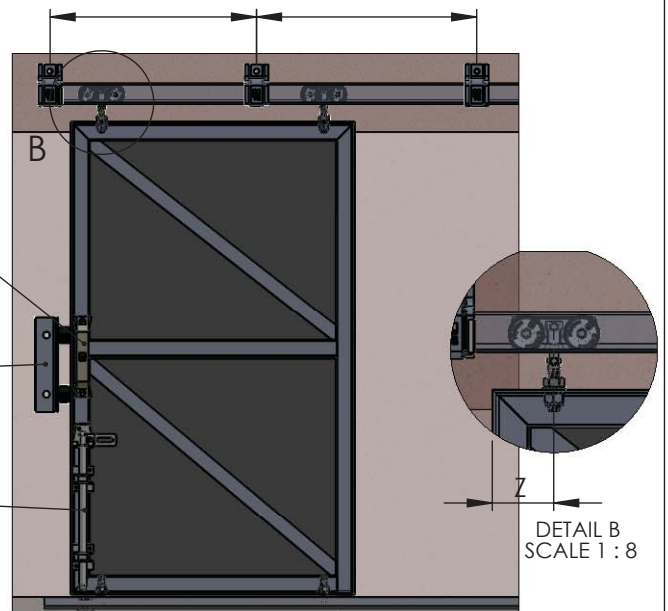

Metal door elevation