

# Splice Installation

1. You will need a #7 drill bit for metal & a ¼"-20 tap.
2. Locate both ends of each track you want to connect together. You only need one hole per end of each track in order to splice them together.
3. Use the template shown to locate each of the holes on the track in the correct placement.

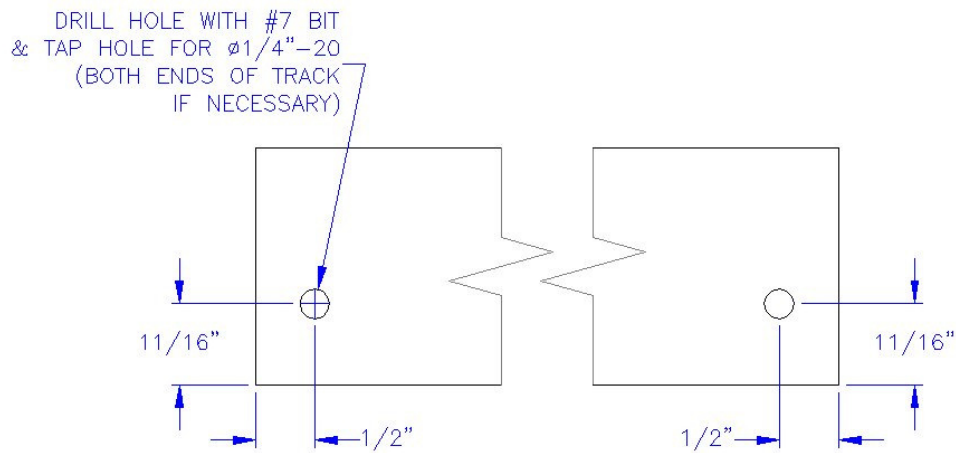

4. Once you have drilled the ends necessary to splice together and installed the track onto the wall along with the splice component kit, then the splice area should look like the picture below after it is complete.

